

# MICRON

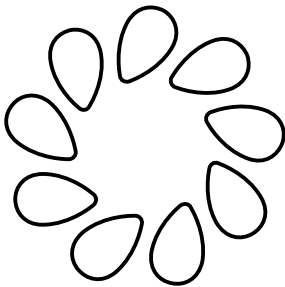

# ***Electrafan 12***

## **Poultry Vaccination Instruction manual**

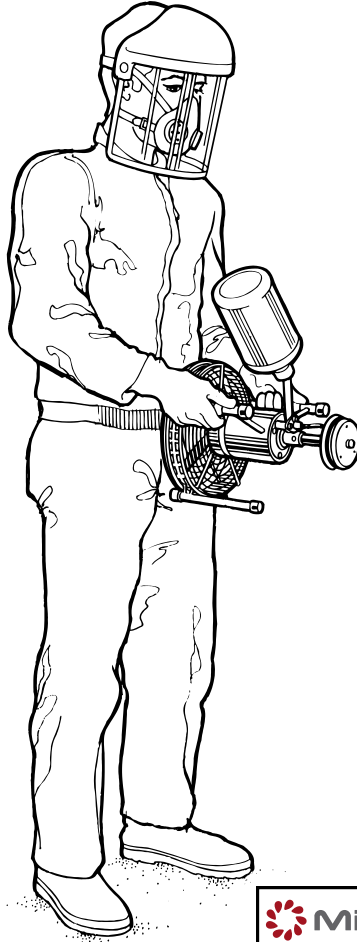

Bromyard Industrial Estate, Bromyard,  
Herefordshire, HR7 4HS, UK  
Tel: + 44 (0) 1885 482397  
Fax: + 44 (0) 1885 483043  
E-mail: [enquiries@micron.co.uk](mailto:enquiries@micron.co.uk)  
URL: <http://www.micron.co.uk>



## **IMPORTANT POINTS**

Please read this manual before using the Electrafan 12.

### **Safety**

- Never touch the disc while it is turning.
- Wear the protective clothing recommended, do not wear clothing such as scarves or ties (may become entangled with the fan).
- Disconnect the battery before servicing the sprayer.

### **Vaccination**

- The Electrafan 12 is recommended for repeat vaccination against I.B., N.D. and T.R.T./S.H.S.
- Verify if droplets of 70µm are suitable under your local conditions (high temperature/low humidity).
- Only vaccinate healthy animals.
- Use fresh, clean, distilled, de-ionised water.
- Gather the birds for easy coverage and reduce light/ventilation during the vaccination.

### **Use/Maintenance**

- Do not put the sprayer/battery under water.
- Do not use disinfectants on parts that may be in contact with the vaccine.
- Do not completely tighten the vaccine bottle to allow air inlet.
- Clean the sprayer and recharge the battery before storage.

# CONTENTS

Page

Important Points .....	1
Description .....	2
Safety and Operator Protection .....	3
Preparing for spraying .....	4
Calibration .....	5
Preparing the Vaccine .....	7
Before spraying .....	7
Cleaning, Maintenance and Storage .....	10
To Service the Motor and Switch .....	11
The Battery .....	11
Troubleshooting .....	12
Parts Diagram .....	13
Parts List .....	14

## DESCRIPTION

The ELECTRAFAN 12 is a light air-assisted hand-held spinning disc Controlled Droplet Application (CDA) sprayer. It is powered by a 12 volt DC rechargeable battery giving about 1½ hours spraying before recharging is required. The sprayer with a full spray bottle weighs 3.25 kg, and the battery weighs 6.6 kg. An electric motor spins the atomiser disc to produce uniformly small droplets which are carried to the target by the airstream generated by the fan. Liquid is fed by gravity.

The ELECTRAFAN 12 can be used for vaccination of broilers, layers and turkeys and is recommended for repeat vaccination against respiratory diseases such as Infectious Bronchitis, Turkey Rhinotracheitis and Newcastle Disease. Low spray volumes of less than 3 litres per house are normally applied allowing operators to treat up to 30,000 broilers, for example, in less than 30 minutes. The method of atomisation used by the ELECTRAFAN 12 gives precise control over droplet size (70 microns), ensuring accurate delivery of vaccine to the eye and upper respiratory tract. Post-vaccinal reaction caused by the production of very small droplets is minimised. The precise control over droplet size also allows the use of low spray volumes which significantly reduces the time spent for both vaccine preparation and application, ensuring minimal disturbance to birds.

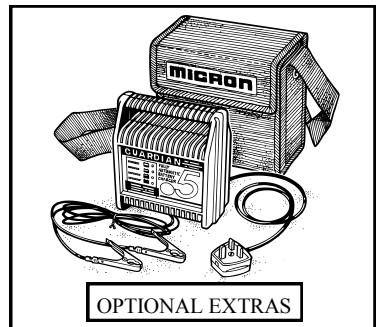
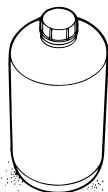
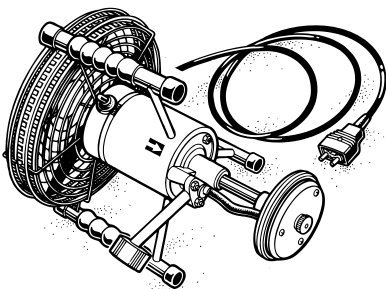

## SAFETY AND OPERATOR PROTECTION

**Always** wear the protective clothing items listed on the product label for mixing and filling. The **minimum** protective clothing required for **spraying** with the ELECTRAFAN 12 is:

- ◆ face shield
- ◆ respirator
- ◆ rubber gloves and boots
- ◆ long sleeved shirt
- ◆ long trousers



Do not put the machine and or battery completely under water. Follow label and data sheet recommendations supplied with the vaccines to ensure that operators are not exposed to potential eye and lung irritants during spraying.

### **Never touch the edge of the atomiser disc while it is turning**

**Always** disconnect the sprayer from the battery before servicing or following 'TROUBLESHOOTING' procedures.

**Never** insert anything through the fan guard with the machine connected to the battery.

**Never** wear loose clothing, e.g. scarves and ties, or any item which could be drawn into the fan.

**Check** the sprayer cable frequently for cuts, abrasions and damage. A faulty cable must be replaced.

### **Note:**

a) Acoustic information: The ELECTRAFAN 12 is a powerful sprayer. the sound pressure level at the operator's ear is 84 dB(A). Using the machine in an enclosed/confined space may cause this level to increase by up to 6 dB(A). The sound power level of the machine is 87 dB(A).

The wearing of suitable ear defenders is recommended when using this machine.

b) Vibration: the weighted RMS acceleration value at the hands when using this machine is 6.3 m/sec<sup>2</sup>.

## PREPARING FOR SPRAYING

Before connecting to the battery, check by hand that the atomiser assembly and fan rotate freely by turning the atomiser assembly in an anti-clockwise direction. (**Do not** touch the edge of the atomiser disc). If they are not free to rotate **do not** attempt to start the sprayer but contact your supplier.

Plug the sprayer into the battery and switch on to check smooth running of the atomiser disc and fan.

The sprayer **must only** be used at the rated voltage. The machine **must** be switched off in the event of power interruption.

If you are using the ELECTRAFAN 12 under particular conditions (very dry environment / high temperatures) you must check that the droplet size generated is still appropriate for your vaccination. When you have prepared the vaccine, fill the spray bottle and fit it to the ELECTRAFAN 12. Do not completely tighten so as to allow entry of air into the bottle.

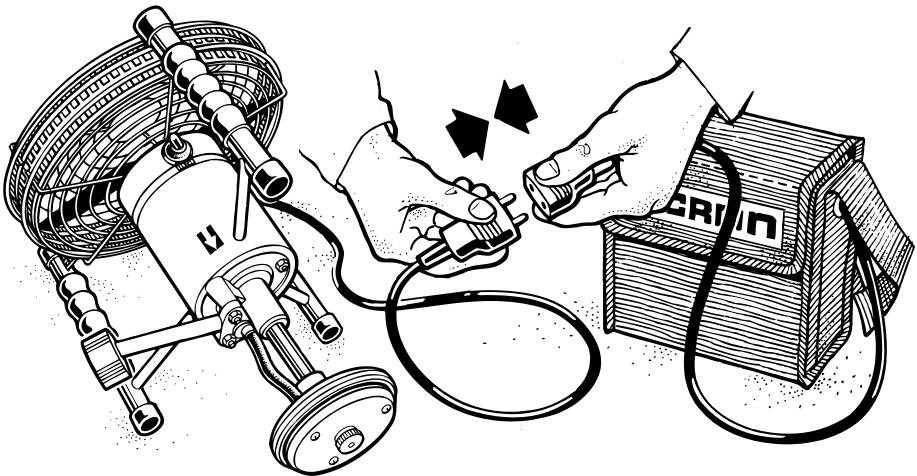

**WARNING:** Sick birds should not be vaccinated. Seek professional help in this case.

**TIP:** Before spraying for the first time with the ELECTRAFAN 12 operation should be checked using only water.

## CALIBRATION

The spray droplet sizes produced by the ELECTRAFAN 12 have been accurately measured (70 microns). The sprayer is capable of producing a very uniform size range of droplets suitable for the delivery of respirable spray vaccines. Spraying should be carried out on a time and volume basis rather than solely a volume per thousand birds. The more time spent spraying the birds the better the vaccine coverage. However, the time allowed for spraying is determined by the length of time during which the shed/house ventilation can be inoperative.

### Nozzle Selection

Choose the appropriate nozzle required for your application or refer to recommendation from your vaccine supplier. To change nozzle and measure flow rate unscrew union nut and refit alternative nozzle. You may measure output over 1 minute with disc removed (do not switch on the sprayer).

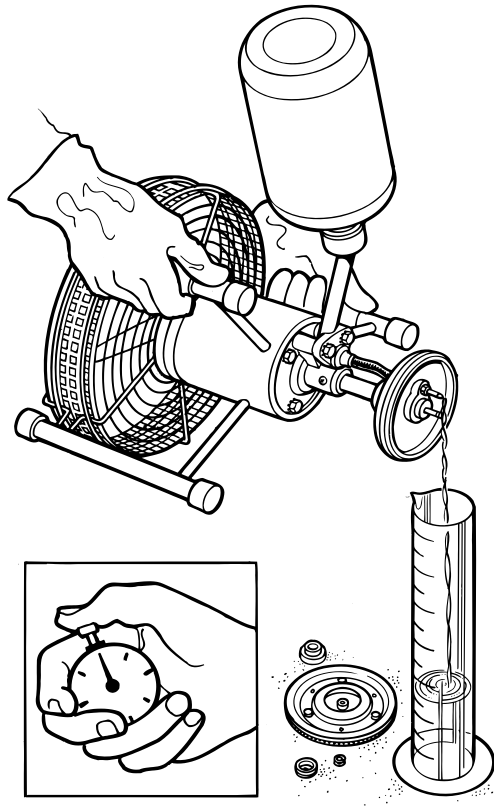

Nozzle flow rates (with water) are:

Nozzle Diameter	Flow Rate (ml/min)	Spray time in minutes for		
		1 litre	2 litres	3 litres
1.1	55	18	36	54
1.5	100	10	20	30
2.0	To be used for higher viscosity/oil based products			

### **Example 1:**

To spray a house containing 25,000 ten day old broilers, depending on ambient temperature, the ventilation can be shut down for approximately 20 minutes without stressing the birds.

In 20 minutes the 1.5 mm nozzle will spray approximately 2 litres.

25,000 doses should be mixed in 2 litres of fresh distilled water and the vaccine sprayed on the birds for 20 minutes.

### **Example 2:**

To spray a house containing 10,000 twelve week old broiler breeders, depending on ambient temperature, the ventilation can be shut down for approximately 20 minutes without stressing the birds.

In 18 minutes the 1.1 mm nozzle will spray approximately 1 litre

10,000 doses of vaccine should be mixed in 1 litre of fresh distilled water and the vaccine sprayed on the birds for 18 minutes.



## **PREPARING THE VACCINE**

Use a clean, disinfectant free, non-metallic calibrated jug for preparing the vaccine mixture. Only use fresh clean distilled or de-ionised water for mixing with vaccine.

Make sure there are adequate washing facilities available for personal cleaning after vaccination i.e. warm water for soap and disinfectant.

Ensure appropriate protective clothing and equipment is worn according to vaccine manufacturers instructions.

1. Read the label carefully and then follow the vaccine manufacturers instructions. If necessary take advice from the vaccine supplier or your veterinarian. Make sure you have a sufficient number of doses to treat all birds.
2. Calculate the volume of water required to vaccinate the birds according to nozzle used and time of application (see 'CALIBRATION').
3. If spraying for the first time carry out a trial run spraying the birds with water only to ensure you apply the correct volume.
4. Wash hands to make sure they are clean and free from soap and disinfectant. Measure volume of distilled or deionised water required in the jug.
5. Remove the metal caps from all vaccine bottles. Submerge the vaccine bottles one by one, remove rubber stoppers under the water and then rinse each bottle to remove all live vaccines before discarding empty bottle.
6. Transfer the mix to the spray bottle. Replace bottle cap.

## **BEFORE SPRAYING**

1. Wear recommended protective clothing (see 'OPERATOR PROTECTION') and ensure birds are healthy. Only vaccinate healthy birds. Consult a veterinarian in case of doubt.
2. Make sure that the battery has been fully charged (if possible the day before spraying so that there is time to recharge the battery if required).
3. Plan a route before spraying (see below).
4. Prepare the vaccine, fill the bottle and screw the bottle on the sprayer. Do always keep the bottle in an upright position during this procedure. Do not completely tighten the bottle to allow inlet of air.
5. Before spraying turn off all ventilation fans and dim the lights as low as possible whilst still being able to see obstacles in the shed/house. In naturally lighted houses it may be beneficial to vaccinate when darkness has fallen.

## During Spraying:

6. To begin spraying; with the machine in the resting position, switch on the fan and atomiser and then turn the sprayer over to invert the bottle and commence liquid flow. Start walking along planned route. Hold the sprayer to one side and walk slowly through the birds. If you need to stop spraying briefly, bring the sprayer back into the resting position. To stop for a longer period you may switch off the fan as well.

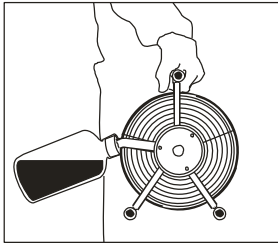

Electrafan 12 in resting position

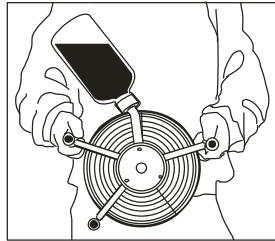

Electrafan 12 in spraying position

Before spraying for the first time use water **only** to check the operation of the sprayer. Put some clean water in the bottle and screw it into the bottle holder. When fitting the bottle into the bottle holder tighten fully and then unscrew by 1/4 of a turn. If this is not done the airbleed may be blocked causing liquid feed to stop. Check for leaks. Switch on the sprayer with the bottle below the atomiser disc and **then** turn the sprayer over so that the bottle is above the atomiser disc (spray liquid will then flow through the feed nozzle onto the atomiser disc). This is the spraying position, and spray will immediately be emitted. **Start walking** as soon as the sprayer has been turned over. Practice using the sprayer by walking along a few metres and then stopping spraying.

The ELECTRAFAN 12 produces small droplets which are barely visible in normal conditions. To check the sprayer output switch on, turn the sprayer into the spraying position and direct the spray onto a suitable surface such as a pane of glass or painted surface for a few seconds. A liquid film or mass of small droplets will be seen.

## Non-caged birds

1. Following a logical and systematic route up and down the house. Divide birds into groups whilst walking through them. Always walk towards the door. Move slowly through the birds with the machine held down at arms length directed slightly downwards at the birds (as a general guide, it is useful to aim the machine at birds approximately 4-5 metres in front of you).

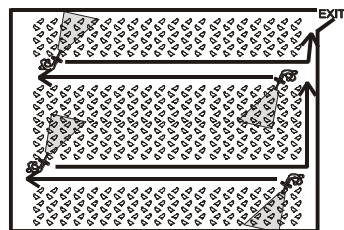

2. As you walk hold the sprayer to one side covering a strip about four to five metres wide on each side of you. It is possible to see birds reacting by shaking their heads as the vaccine reaches them.
3. Continue walking through the birds until all the vaccine has been sprayed. Walk through the same birds more than once if possible.

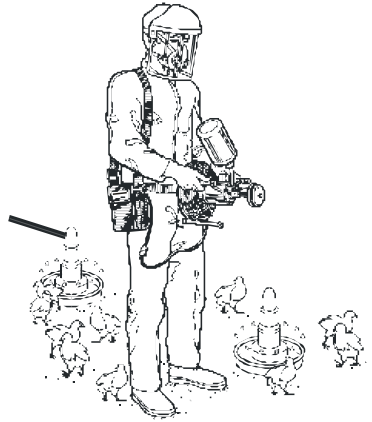

**TIP: Where stocking densities are low, it may be necessary to pen birds into smaller areas in order to ensure ease of coverage.**

### Caged birds

Walk slowly along the front of each row of cages spraying directly at each cage. If possible spray from at least two metres away. It may be useful to walk through the house with the fan switched on but without vaccine whilst the ventilation is still in operation in order to clear as much dust from the cages prior to vaccination.

In order to minimise stress to the birds during hot weather it is preferable to carry out vaccination early in the day at the coolest time. Locking ventilation on full for a period of time prior to vaccination in order to lower the temperature may also be useful during periods of hot weather.



**IMPORTANT: RESTORE VENTILATION AND LIGHTS IMMEDIATELY AFTER VACCINATING.**

To stop spraying at any stage invert the sprayer to the resting position.

## CLEANING, MAINTENANCE AND STORAGE

**IMPORTANT:** Before starting the maintenance of your ELECTRAFAN 12 always disconnect the battery from the sprayer.

After vaccination is complete, wash out any residues in the spray bottle with clean water. It is also recommended to spray out a little water to clean the disc and nozzle. Occasionally it may be necessary to remove the atomiser disc and the fan guard to clean them with hot soapy water.

**IMPORTANT:** Never use any disinfectant in the vaccine bottle or on the atomiser disc assembly.

### TO CLEAN ATOMISER ASSEMBLY

**Always** disconnect the sprayer from the battery before servicing.

Hold the fan by inserting a pencil or similar between the guard rings near the nameplate. Remove the atomiser spindle nut by turning clockwise when facing the atomiser assembly (left hand thread). If the nut is tight loosen using pliers. Pull off the atomiser assembly, clean with hot water, then drain and dry.

Alternatively, dismantle the atomiser assembly by releasing the 3 clamp screws and nuts. Clean carefully. When re-assembling be certain to replace the two spacer washers on each screw before re-fitting the stainless steel rear collector disc.

Check that the bearing cover is in place, then place the atomiser assembly on the shaft, followed by the atomiser spindle nut (left hand thread). To tighten hold the fan as above, turn the nut anti-clockwise until finger tight, then rotate the atomiser assembly anti-clockwise. **Do not** overtighten.

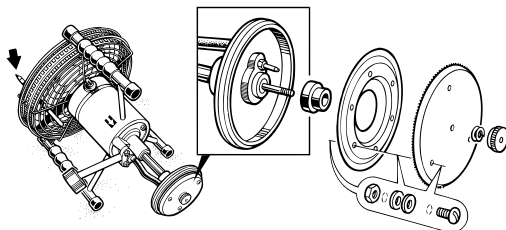

### STORAGE

Before storing the ELECTRAFAN 12 for long periods clean the fan guard with a small brush to remove any deposits and wipe the metal components with an oily rag to help combat corrosion.

Store the sprayer in a clean dry place away from direct sunlight. The battery should be recharged before storage and stored in a cool dry place.

## **TO SERVICE MOTOR AND SWITCH**

***(Only to be carried out by qualified Service Engineers)***

Proceed as follows:

1. Remove handle caps (5) and guard retainer screws (31).
2. Remove outer fan guard and circular guard ring (4+8).
3. Remove fan and inner guard (15+4).
4. Remove fan drive pin (22) (tight push in), slinger (67) and washer (43).
5. Remove switch cover (6) (two retainer screws near fan shaft). Note position of large 'O' ring (66) and ensure this is re-fitted to the motor housing before re-assembly.
6. Gently pull switch cover clear of the fan shaft and move to one side to expose motor brushes (24), switch and internal wiring.

When re-assembling:

1. Reverse the above procedure.
2. Make sure the fan drive pin is located in the grooves in the fan hub. This prevents the fan shaft from rotating when the fan nut is tightened.

N.B. Replacement brushes for the motor are available from Micron. If the armature or bearings need replacing, a new motor will be required.

## **THE BATTERY**

Try to empty the battery completely before recharging. The battery should be completely charged before storage. Normally the battery allows one and a half hours of spraying time.

The Micron battery supplied is a Yuasa NP valve regulated lead acid sealed maintenance free 17Ah (amp hour) 12V D.C. non-spillable type. **Do not** check electrolyte specific gravity or add water, which will permanently damage the battery. Over discharging will also damage the battery thus recharge as soon as possible after use. When charging the battery using the recharger supplied, connect the recharger leads to the battery terminals (after unplugging the ELECTRAFAN 12 from the battery) and then switch on at the mains. If the ELECTRAFAN 12 is used with other 12V D.C. batteries or rechargers consult the manufacturer for recharging information.

The special safety recharger supplied by Micron will avoid accidental overcharging of the Micron battery.

## TROUBLESHOOTING

FAULT CHECKING CHART	
<b>Problem</b>	<b>Procedure</b> <b>N.B. <u>always disconnect the sprayer from the battery</u></b>
<p>Motor fails to start</p> <ol style="list-style-type: none"> <li>1. Switch</li> <li>2. Battery run down</li> <li>3. Loose battery connections</li> <li>4. Blown fuse</li> <li>5. Stiff or seized motor</li> <li>6. Faulty switch, internal wiring or motor</li> </ol>	<p>Check switch is in ON position.</p> <p>Test battery with a voltmeter or a suitably wired 12 volt bulb. Recharge if necessary ensuring battery fuse is not blown.</p> <p>Check that all connections are clean and secure (battery terminals, plug connector) and that the battery is fully charged.</p> <p>If the battery is fully charged, check the 10amp anti-surge fuse inside carrying case near the plug connector socket.</p> <p>Atomiser assembly should be free to turn in an anti-clockwise direction. Some friction from motor brushes is normal but if it is difficult to turn by hand contact your supplier.</p> <p>Contact your supplier.</p>
<p><b>Motor runs slowly</b></p> <ol style="list-style-type: none"> <li>1. Battery run down</li> <li>2. Friction in atomiser assembly or motor</li> <li>3. Poor electrical connections</li> <li>4. Worn or defective switch contacts</li> <li>5. Defective motor armature</li> </ol>	<p>Test battery with a voltmeter or a suitably wired 12 volt bulb. Recharge if necessary (see 'THE BATTERY').</p> <p>Atomiser assembly should be free to turn in an anti-clockwise direction. Some friction from motor brushes is normal but if it is difficult to turn by hand contact your supplier.</p> <p>Check systematically all external wiring and connections, especially in plugs and battery.</p> <p>Contact your supplier.</p> <p>Contact your supplier.</p>
<p><b>Fails to spray, product leaking from air bleed hole in feed line</b></p> <ol style="list-style-type: none"> <li>1. Blocked feed line</li> </ol>	<p>Remove the spray bottle. Remove and clean feed nozzle.</p>
<p><b>Intermittent spraying</b></p> <ol style="list-style-type: none"> <li>1. Blocked air bleed in feed line</li> </ol>	<p>Remove the spray bottle and clean threads on the bottle and in the neck of the feed line. When fitting the bottle into the bottle holder tighten fully and then unscrew by 1/4 of a turn. If this is not done the air bleed may be blocked causing liquid feed to stop. Check the air bleed hole is clear.</p>

# ELECTRAFAN 12 PARTS DIAGRAM

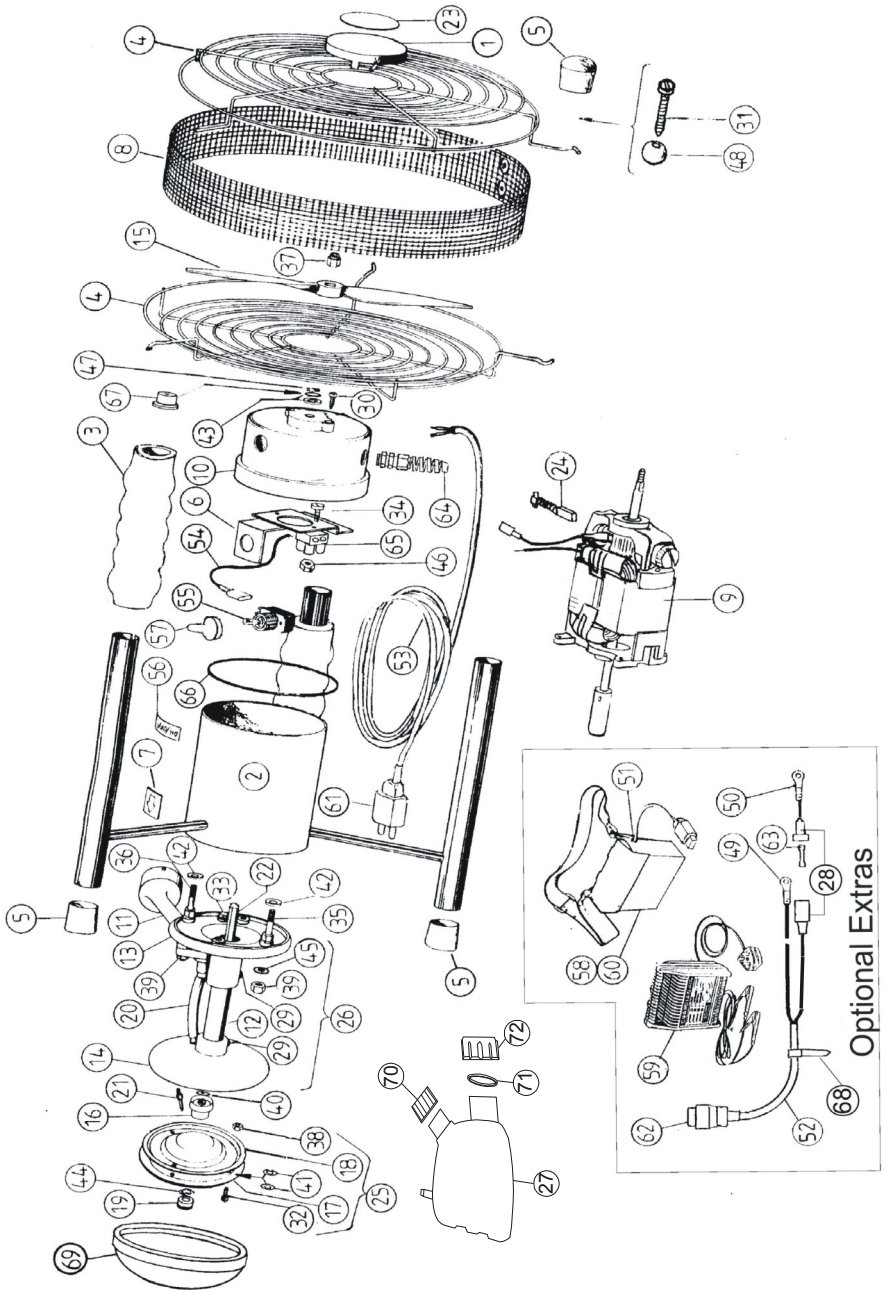

# ELECTRAFAN 12 PARTS LIST

Item No.	Description	Part No.	Qty.	Item No.	Description	Part No.	Qty.
1	Label plate	T/4103	1	35	Screw, D/E 2.BA x 1-5/8"	T/5128	3
2	Motor housing with handles	T/A4104	1	36	Screw, D/E 2.BA x 2-5/8"	T/5129	1
3	Hand grip	T/4109	2	37	Nut, 1/4" BF, nyloc	T/5132	1
4	Circular fan guard	T/4111	2	38	Nut, 4.BA, lock, brass	T/5151	3
5	Cap, plastic	7063	6	39	Nut, 2.BA	T/5136	5
6	Switch bracket	T/4129	1	40	Washer, 4.BA brass, large	T/5205	1
7	Label - spray direction	T/4145	1	41	Spacer No. 6 x 0.270" x 20 G, S/S	T/5211	6
8	Outer guard ring assembly	T/B4159	1	42	Washer, 2.BA x 3/8" o.d.	T/5221	5
9	Motor assembly 12 volt	T/A4501	1	43	Washer, 6mm	T/5225	2
10	Fan end cover moulding	T/4506	1	44	Washer, DC spring 4.BA	T/5234	1
11	Bottle holder and feed line assembly	T/A4507	1	45	Washer, Lock ext 2.BA	T/5253	6
12	Extension tube and bearing	T/A4509	1	46	Nut, 6.BA	T/5272	1
13	Atomiser support	T/4511	1	47	Rollpin 3/32" x 1/2"	T/5304	1
14	Atomiser back plate with nozzle holder	T/A4512	1	48	Bead 9/16" plastic	T/5309	3
15	Fan, 23 x 10	T/4513	1	49	Crimp connector, 2.BA (blue)	T/6015	1
16	Atomiser bearing cover	T/4514	1	50	Crimp connector, 1.BA (red)	T/6017	1
17	Atomiser disc - front plate	T/4515	1	51	Cable tie	T/6031	1
18	Atomiser collector plate	T/4516	1	52	Cable, 2 core - 0.5M	T/6041-0.5M	1
19	Atomiser retainer nut	T/4517	1	53	Cable, 2 core - 1.5M	T/6041-1.5M	1
20	Chemical feed tube (65mm)	T/4518-65mm	1	54	Switch connector lead	T/A6042	1
21	Feed nozzle - 0.9mm	T/4519-0.9mm	1	55	Switch	T/6043	1
	Feed nozzle - 1.1mm	T/4519-1.1mm	1	56	Off/on label	T/6061	1
	Feed nozzle - 1.3mm	T/4519-1.3mm	1	57	Switch cover	T/6062	1
	Feed nozzle - 1.4mm	T/4519-1.4mm	1	58	Battery pouch	T/6099	1
	Feed nozzle - 1.6mm	T/4519-1.6mm	1	59	Battery charger (UK plug)	T/6101	1
	Feed nozzle - 2.0mm	T/4519-2.0mm	1	59	Battery charger (European plug)	6046	1
22	Atomiser drive shaft	T/4520	1	60	Battery, 12 volt DC rechargeable (17Ah)	T/6102	1
23	Machine identification label	8677	1	61	In-line connector (male)	T/6103	1
24	Motor brush	T/4804	2	62	In-line connector (female)	T/6104	1
25	Atomiser assembly	T/A4827	1	63	Fuse, 12.5 Amp, 1/4 x 1 1/4" (T)	6759	1
26	Atomiser extension assembly	T/A4828	1	64	Cable gland	T/6110	1
27	Bottle with cap, 1 litre	5265A	1	65	Electric connector block	T/6113	1
28	Fuse holder, in-line, 20 Amp	7526	1	66	'O' ring (BS 043)	T/6118	1
29	Screw, No. 6 x 1/4" S/T	4988	2	67	Slinger	T/6119	1
30	Screw, No. 4 x 5/8" S/T	4677	2	68	Cable tie (medium)	6018	1
31	Screw, No. 10 x 1-1/2" S/T	T/5007	3	69	Atomiser cover	T/2018	1
32	Screw, 4.BA x 1/4" brass roundhead	T/5114	3	70	Bottle Cap—Black	3216	1
	Snap ring, internal bore 13mm	T/A4509	1	71	Cork Washer	5353	1
33	Screw, 2.BA x 1-1/2"	T/5115	1	72	Bottle Cap—Black	4489	1
34	Bolt, 6.BA x 1/2" roundhead	T/5124	1				



## DECLARATION OF CONFORMITY

Name of manufacturer or supplier: Micron Sprayers Ltd.

Full postal address: Bromyard Industrial Estate,  
BROMYARD, Herefordshire

Country of origin: England

Post code: HR7 4HS

Description of Product: Battery powered, hand-held  
agricultural spraying  
machine.

Name and model number of machine: ELECTRAFAN 12

Place of Issue: Bromyard, England

Name of authorised representative: G. S. Povey

Position of authorised Representative: Joint Managing Director

### DECLARATION:

I declare that as the authorised Representative, the above information in relation to the supply/manufacture of this product is in conformity with the requirements of the Machinery Directive 2006/42/EC and complies with the relevant essential health and safety requirements.

Signature of authorised Representative:



---

# NOTES



